



GX2



NYALIC
Clear Surface Protectant

Gear Boxes coated in Nyalic to help prevent corrosion.

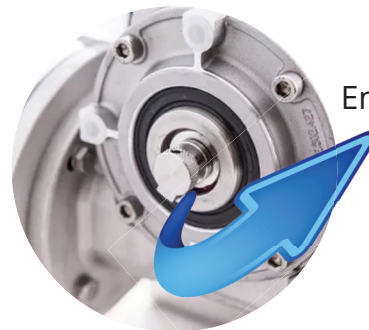
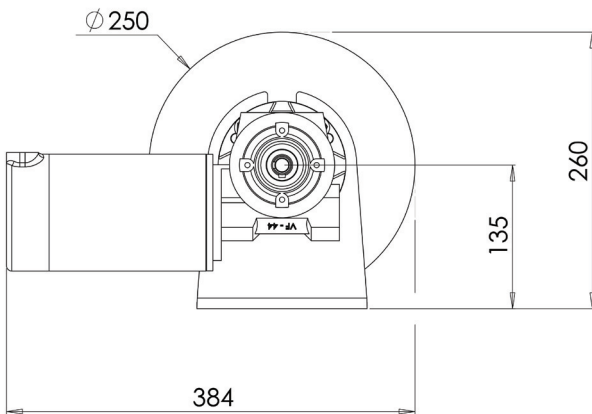

Emergency manual release

Performance, reliability and raw power in a compact frame design, the GX2 is the answer for most trailer boat fishermen. Thanks to the well oversized gearing and motor this unit can easily be fitted to boats to 8m for saltwater use and much larger for freshwater applications.

- Huge 1000W motor
- Perfect for wet wells and deck mounts
- Boats to 8m
- Fast drop/retrieval rating
- 6mm 316SS plate construction
- Fully sealed motor and gearbox
- 24 variable motor positions
- 22kg approximate weight of unit

Installation kit includes: 316 stainless steel backing plate, 400amp solenoid, 120amp circuit breaker, switch panel, nuts and bolts.

Model	Motor Size	Drop/Retrieve	Max Pull (Empty Drum)	Max Pull (Full Drum)	Recc. Max Working Load	Rope/ Chain Capacity	Boat Size (metres)	Holding at Anchor
GX2 250mm drum	1000 watts	46metres per minute	1377kg	362kg	110kg	90m x 8mm + 7m x 6mm	5-8	3T